



ELEVATE SMART TOUCH PANEL

USER MANUAL

The **Aziot Elevate** series is an elite smart Wi-Fi touch solution designed for modern interiors. Featuring a **Toughened Glass** surface and **Premium Finish Bezels**, it provides sophisticated control via touch, smartphone, or voice assistants.

PRODUCT RANGE & DESIGN

Crafted with premium materials for high-end durability and aesthetics.
Black Panel: Toughened Black Glass with a **Gold** Premium Finish Bezel.
White Panel: Toughened White Glass with a **Silver** Premium Finish Bezel

Model Variant	Size	Switches	Fans	Socket & USB
Aziot Elevate 2M-4SW	2 Module	4	-	-
Aziot Elevate 4M-4SW+SKT	4 Module	4	-	10A + 18W (A+C)
Aziot Elevate 4M-2SW+1F+SKT	4 Module	2	1	10A + 18W (A+C)
Aziot Elevate 8M-8SW+SKT	8/6 Module	8	-	10A + 18W (A+C)
Aziot Elevate 8M-6SW+1F+SKT	8/6 Module	6	1	10A + 18W (A+C)
Aziot Elevate 8M-4SW+2F+SKT	8/6 Module	4	2	10A + 18W (A+C)

TECHNICAL SPECIFICATIONS

AC SPECIFICATIONS	
Operating Input Power Range	220-240 VAC, 50 Hz
Maximum Load Per Output	
Resistive Loads	1000W per channel
LED Light	150W or 5 Lights per channel (Whichever is higher)
LED Strip/Profile	150W (Strictly limit to 1 strip per output)
Fixed Inductive Loads	1000 VA
Fan	120 W - AC Induction Fan Only BLDC Not Supported.
Universal Socket	10A Capacity
USB	18W Total (Supports QC & PD fast charging)
General Specifications	
Power Consumption when loads off	<0.2 W
Power Consumption when loads on	<1 W
Touch Surface Raise Temperature	10°C to 30°C
Working Temperature	10°C to 70°C
Relative Humidity	Operating 5%RH to 95%RH Non-Condensing Storage 5%RH to 95%RH Non-Condensing
RF Frequency	2.4 GHz

INSTALLATION & AUTO-CALIBRATION

Check the Wi-Fi signal strength at the switch board, signal strength should be good, Signal strength should be greater than -50dBm, If it is less than -50dBm then adjust the router near to the switch board.

WARNING: Installation must be performed by a certified electrician. Ensure the main MCB is **OFF** before wiring.

Open the Switch board top cover. Remove all the connections of the loads from the switch board and label them with numbers based on the load connections sequence to the switches. Identify and separate the Neutral and Line supply in the switch board.

1. Wiring: Connect Phase (Line) and Neutral to inputs.

Connect loads to designated terminals as per the mentioned connections in Wiring Diagram section.

2. Mounting: Remove the glass panel carefully.

Screw the module frame to the gang box.

3. Attaching Glass: Align the **Toughened Glass** over the bezel and press firmly at the corners until it "clicks."

4. Auto-Calibration: Turn ON the power. Do not touch the panel for 10 seconds while the sensors perform an internal calibration.

CONNECTION & WIRING GUIDE

IMPORTANT: Before removing your existing switchboard, **label every wire** (e.g., Inverter, Mains, Fan, Light 1). To ensure safety and prevent

MCB tripping, always follow the load distribution of your previous wiring.

Universal Wiring Symbols

- **L / Line:** Live Input (Power Source)
- **N / Neutral:** Common Return Path. The Neutral should be common for the smart Panel and Loads (lights/Appliance/Fans)
- ⊗ : Load Outputs (Lights/Appliances)
- ⚙ **Fan:** Fan Output (Only Inductive AC Fan)

Multi-Line Wiring

The 8-Module variant features three input terminals: **Line**, **Line-1**, and **Line-2**. This allows you to split your power sources (e.g., Inverter vs. Raw Power).

Scenario A: Dual Power (Inverter + Raw Mains)

- **Line & Line-1:** Connect the **Inverter Live** wire to both "Line" and "Line-1." This ensures the smart panel stays powered and controls your backup lights during a power cut.
- **Line-2:** Connect the **Raw Power (Mains)** wire here. These loads will only work when city power is available.
- **Benefit:** This prevents the inverter from being overloaded by heavy appliances while keeping your smart controls active.

Scenario B: Single Power Source

- If you do not have an inverter, you must **loop/bridge Line, Line-1, and Line-2 together** using a single live wire.

WIRING DIAGRAM

1. Aziot Elevate 2M-4SW

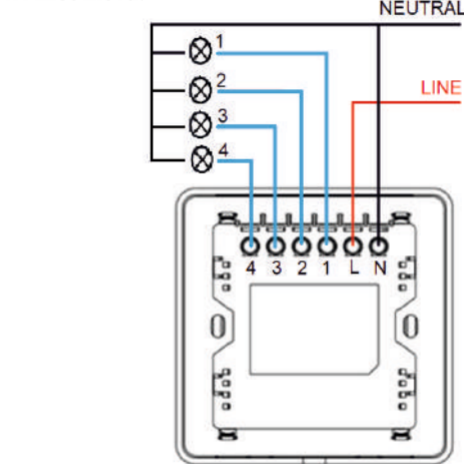

1. Connect the common Neutral to **N** and Main Line to **L**.
2. Connect upto 4 Lights to the terminals 1 to 4.
3. Ensure the total load does not exceed as per the Load recommendations.

2. Aziot Elevate 4M-4SW+SKT

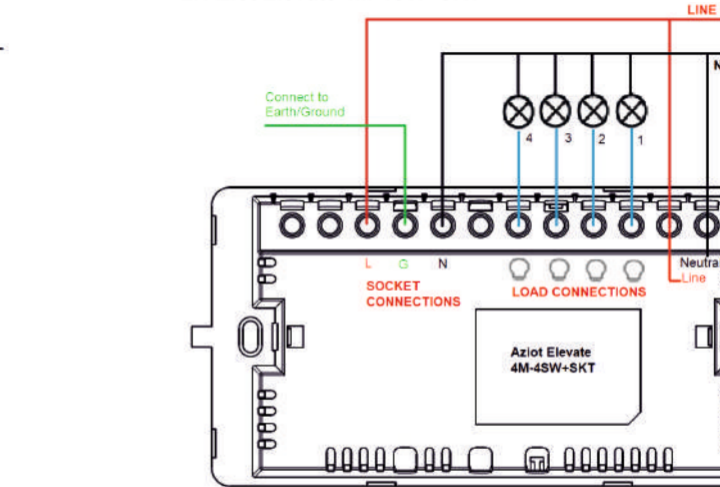

1. Connect **Neutral (N)** to the common neutral point.
2. Connect **Main Line (L)** to the input terminal.
3. **Socket Isolation:** For heavy appliances, use a separate live wire for the socket input to avoid auto-tripping the MCB.
4. Connect only light loads to **1,2,3 & 4** terminals.

3. Aziot Elevate 4M-2SW+Fan

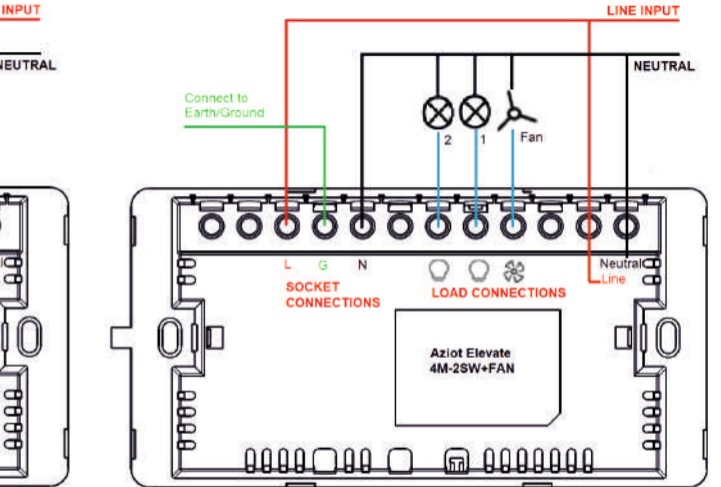

1. Connect **Neutral (N)** to the common neutral point.
2. Connect **Main Line (L)** to the input terminal.
3. **Socket Isolation:** For heavy appliances, use a separate live wire for the socket input to avoid auto-tripping the MCB.
4. Connect only light loads to **1,2 and Fan Wire** to the designated terminals.

4. Aziot Elevate 8M-8SW+SKT

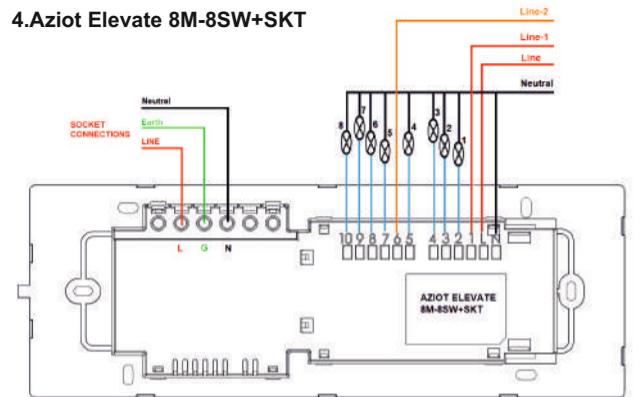

- 1.Line (Main-L):** Must be connected to a live source (preferably Inverter).
- 2.Line-1(1) & Line-2(6):** Distribute your "Inverter Loads" to Line-1 and "Mains Loads" to Line-2.
- 3.Cross-Check:** Connect only Light Loads to the output terminals. Ensure that the neutral is common across all circuits.
- 4.Load Distribution**
Line-1(1) Power Source for Outputs Terminals 2,3,4 & 5
Line-2 (6) Power Source for Output Terminals 7,8,9 & 10.

5. Aziot Elevate 8M-6SW+Fan+SKT

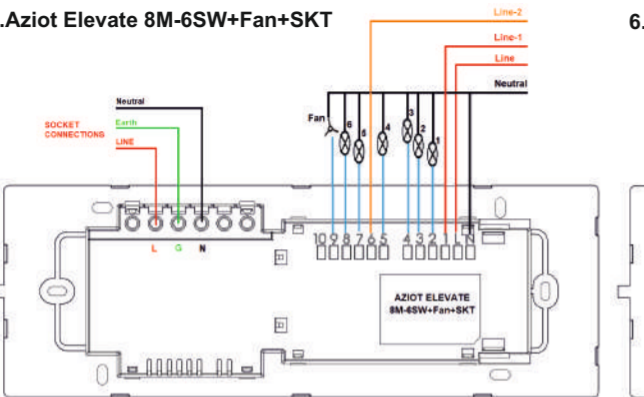

- 1.Line (Main-L):** Must be connected to a live source (preferably Inverter).
- 2.Line-1(1) & Line-2(6):** Distribute your "Inverter Loads" to Line-1 and "Mains Loads" to Line-2.
- 3.Cross-Check:** Ensure that the neutral is common across all circuits.
- 4.Load Distribution**
Light Loads: 2,3,4,5,7 & 8 **Fan Load:** 9
Line-1(1) Power Source for Outputs Terminals 2,3,4 & 5
Line-2 (6) Power Source for Output Terminals 7,8 & 9(Fan).

6. Aziot Elevate 8M-4SW+2Fan+SKT

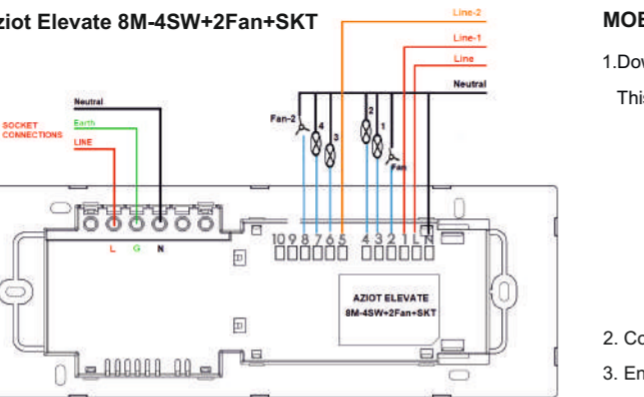

- 1.Line (Main-L):** Must be connected to a live source (preferably Inverter).
- 2.Line-1(1) & Line-2(5):** Distribute your "Inverter Loads" to Line-1 and "Mains Loads" to Line-2.
- 3.Cross-Check:** Ensure that the neutral is common across all circuits.
- 4.Load Distribution**
Light Loads: 3,4,6 & 7 **Fan Load:** 2 & 8 Terminal Points
Line-1(1) Power Source for Outputs Terminals 2(Fan), 3 & 4.
Line-2 (5) Power Source for Output Terminals 6,7 & 8(Fan).

MOBILE APP PAIRING

- Download the Smartlife App onto your smartphone.
- Connect your mobile to 2.4 Ghz Wi-Fi network.
- Enable the Location & Bluetooth in your mobile.

This App available for both iOS and Android devices.



2. Connect your mobile to 2.4 Ghz Wi-Fi network.
3. Enable the Location & Bluetooth in your mobile.

Indicator LED Status (Default)

- **ON State:** Blue LED (All Indicators)
- **OFF State:** White LED (All Indicators)
- (Colors can be fully customized via App Settings)

Step-by-Step Pairing Flow

- 4.Initiate:** Press and hold any one switch button for **10 seconds**. All indicators on the panel will turn **Blue once**, and then **all indicators** will start blinking in **White**.

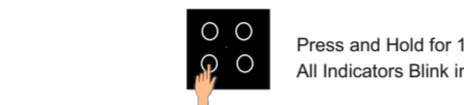

- 5.Confirm:** Release the button, then immediately press and hold the **same button again for 10 seconds**.

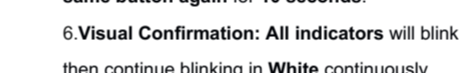

- 6.Visual Confirmation:** All indicators will blink in **Blue three times**, then continue blinking in **White** continuously.
7. Tap the icon "+" on the top right corner of the 'Smart Life' App, then select Auto Scan, and the device will be automatically discovered and click 'Go to add' on the prompt.
8. Tap the icon "+" besides the bluetooth device.
9. Follow the app instructions to connect the Smart Touch Panel to your Wi-Fi network

CONNECTING TO VOICE ASSISTANT

- Search and enable "Smart Life" Skill in Alexa and Google Home.
- Follow the on-screen instructions to complete the Voice Assistants Setup.



ADVANCED APP CONFIGURATIONS

- ALS (Ambient Light Sensor):** When enabled, indicator brightness automatically changes based on room light (dims at night, brightens during the day).
- Backlight Customization:**
ON Color: Red, Blue, or White.
OFF Color: Red, White, or Blue.
Brightness: Manual adjustment from **0% to 100%** (if ALS is off).
- Button Mode Selection:**
Bistable Mode (Default): Best for **Lights and Fans** (Standard Toggle).
Monostable Mode: Best for **Doorbells** or **Scene Switches** (Active only while pressed).
- Power-On Status:** Set behavior after a power cut: **ON, OFF, or Restart Memory**.

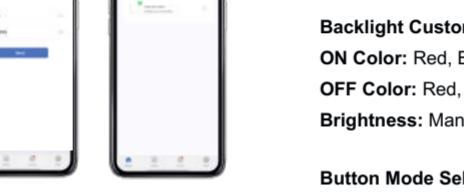

USAGE ENVIRONMENT & SAFETY

- **Indoor Use Only:** This product is designed strictly for indoor environments.
- **Exposure Warning:** Do not install the device in outdoor areas or locations with direct sunlight exposure.
- **Moisture Protection:** Keep the panel away from high moisture, steam, or areas where water splashing may occur.
- **Cleaning:** Use only a soft, dry microfibre cloth. Do not use water, liquid cleaners, or chemicals.
- **Sensor Care:** If touch sensitivity becomes erratic, restart the power at the MCB and allow 10 seconds for auto-calibration without touching the glass.

For Any Technical Assistance

- +91- 88866 35918
- support@aziot.life
- AZIOT HOME AUTOMATION

