

Elevate Air Purifier

Aziot
Air & Smart Solutions

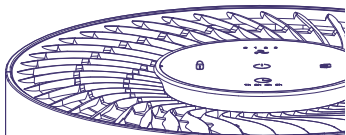

User Manual



Aziot

1
Year
Warranty

Scan for Warranty
Registration



Customer Care : +91 88866 35918
support@aziot.life

Website: www.aziot.life

Follow us on: [Aziot.life](https://www.aziot.life)

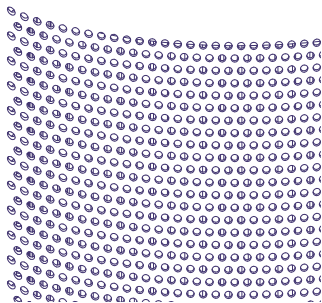

Technical Specifications

Model	AZ235
Power Supply	220-240V
Rated Power	33W
CADR	300m ³ /h
Noise Level	55 dB
Dimensions	238*238*410 mm
Net Weight	3.5KG

Safety Instructions

This appliance is a Floor-type air purifier, to reduce the risk of fire, electric shock, or serious injury, basic safety precautions should always be followed when using electrical appliances. Please read and follow all the safety instructions before using and only use this air purifier as described in this manual.

Warning:

- To reduce the risk of fire or electric shock, do not use this fan with any solid-state speed control device.
- Do not use the air purifier in wet or humid environments, or outdoors. This appliance is designed for indoor use only.
- Do not put the air purifier on an uneven floor such as a bed or sofa. Always make sure to place the air purifier on a flat surface before operating. Leave more than 20 cm distance between the air purifier and the wall.

Safety Instructions

- Do not place the air purifier near sources of heat, such as stove tops, ovens, or radiators.
- Do not handle the unit with wet hands. Thoroughly dry your hands before handling any part of the air purifier.
- Do not use without removing the plastic wrap from the air purifier and filters.
- Do not attempt to use other filters with this appliance. Only use air replacement filters for this unit.
- Do not block the air inlet, outlet, as well as the sensor, by anything.
- Do not insert fingers or objects into the air outlet.
- Do not immerse air purifier in liquids or clean the appliance with any liquid to avoid electric shock and/or electrical fires.
- Do not run the power cord under carpeting, rugs, furniture, or appliances. Place the power cord away from high-traffic areas.
- Do not operate the unit if the power cord or plug is damaged. Doing so may result in injury or damage to the unit.
- Do unplug the appliance from the power supply before servicing.
- Do inspect the unit frequently. Dirt that has collected should be removed regularly to prevent excessive accumulation that may result in flash-over or fire.
- Do not repair it by yourself if the air purifier does not work, it will void your warranty. If your appliance is no longer working, damaged, or not functioning properly, discontinue use, unplug immediately and contact customer support immediately.

The Structure of Air Purifier

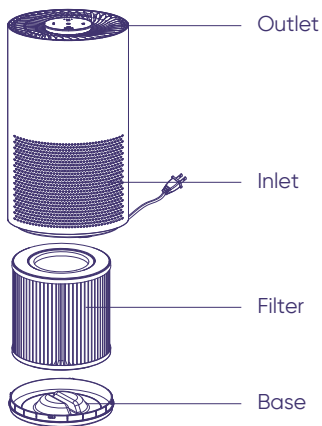

Purification System



4 in 1 purification system

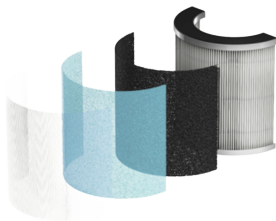

4 in 1 filtration system

Purification System

Your new Elevate Air Purifier uses advanced technology to clean the air in your room. Uses 4 advanced technologies to keep your air clean, capturing airborne particles:

PP & Pre-filter

PP Pre-filter to removes larger particles including hair, fibers, dander, and others.

Nano-silver antibacterial filter.

Strong antibacterial ability, antibacterial effect is significant, lasting, can remove the large particles in the air, such as dust, hair, etc., inhibit bacterial growth.

Activated carbon filter.

Granular activated carbon filter helps reduce odors and eliminate odors.

H13 HEPA filter.





H13 HEPA filter removes ultrafine particles from the air, including allergens, smoke and other impurities.

Buttons and Indicators

Control Panel



Buttons and Indicators

	<p>Short press it to power on/ off the unit.</p>
 1h 2h 4h 8h	<p>Timer button:1/2/4/8h</p>
<p>S 1 2 A</p> 	<p>Fan speed buttons: Sleep mode, Levels 1, 2, A In the Auto, the Air Purifier changes the wind speed and displays the air quality status according to the current air quality. In the Sleep mode, all the lights on the control panel shall turn off and the Air Purifier will operate at the lowest fan speed.</p>
	<p>Filter reset button. When the filter has been used for over filter lifespan, this button light will flash indicating you need to install a new filter. After changing filter, press and hold the button for 3 seconds, the flashing light will reset and have no problems to continue using.</p>
	<p>Short press the button to turn/off light WiFi Mode : Press the button for 3 seconds to enter the WiFi function.</p>

Air quality indicator

Index	(ug/m ³)	Air Quality	Speed	Color
PM2.5	1-75	Good	1	Green
	76-150	Moderate	2	Yellow
	150-500	Unhealthy	3	Red

Let's Set it Up

1. Download Smart Life APP



To download the Smart Life Smart app, Scan the QR code or search " Smart Life " in the Apple App Store® or Google Play Store.

2. Open the Smart Life App. Register and Log in.

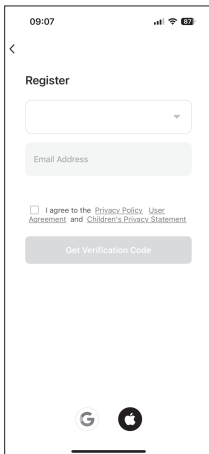
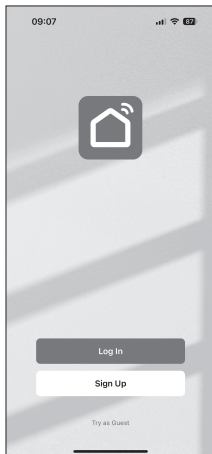

(Sign Up)

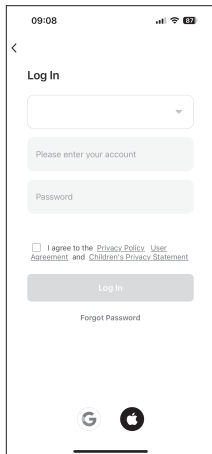

(Log In)

3. Go to home page and pair the product.

Please refer to page 7-8 and follow the steps on How to connect the product.

Let's Set it Up

Step 1 :

Short press the "  " button to turn on the product.

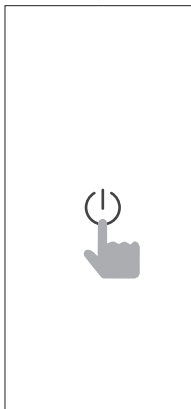

Step 2 :

Long press the "  " button 3s, the " WIFI " indicator will blink. Enabling Wi-Fi matching.

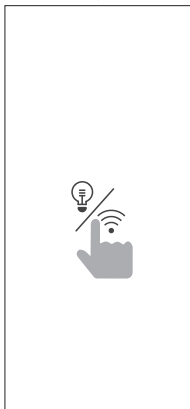

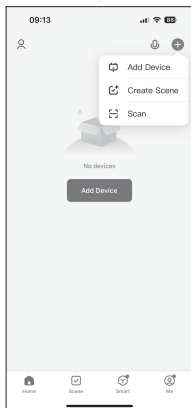

Step 3 :

Click on "Add Device"



Before following the steps

- Ensure that you are connected to a secure 2.4GHz Wi-Fi network during setup. Do not use a 5GHz network, as it will not successful pairing.
- Make sure the product is power up. Turn on your phone's Bluetooth as the same time.
- Long press the "  " button 3s, the " WIFI " indicator will blink to enable the pairing mode.
- If the product is still not connected for more than 3 minutes, Long press the "  " button of the product again.

Air Purifier Maintenance

1. Cleaning the unit.

- Please turn off the power and unplug power line before cleaning the air purifier.
- To remove dust, lightly wipe the unit with a soft, clean cloth. If needed, wipe the unit with a clean damp cloth, then immediately dry with a clean dry cloth.
Don't use alcohol, oil, benzene to clean the unit.
- Do not immerse the unit in water.

Note:

The HEPA filter, Nano-silver anti-bacteria filter, and the activated carbon filter cannot be reused, cleaned, or replaced after being used. Please don't wash them by water.

2. Replacing the filter.

To maintain the performance of the air purifier and purification effect, we advise to replace the filters every 3000H.

1. Unplug the air purifier from the electrical outlet.
2. Twist the bottom panel counter-clockwise to remove the panel.

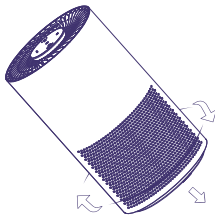

3. Remove the old filter and dispose of it properly. The filter is not recyclable.

Air Purifier Maintenance

4. Remove the new filter packaging and insert it into the air filter.

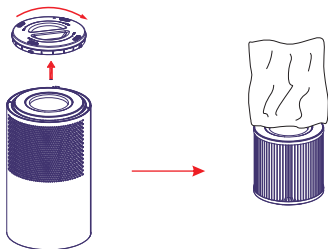

5. Turn it clockwise to tighten the bottom panel.

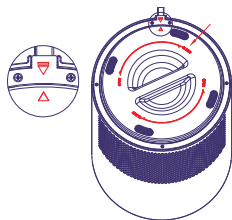

6. Place the air purifier on the table again and plug it back into the electrical outlet. The air purifier will automatically clean the air again.

Note:

The actual replacement frequency depends on its service length and air quality. If it is on day and night or your surrounding air is highly polluted, it will take shorter to replace. On the contrary, it will take longer.

Please don't forget to press the button of "Filter Reset " for 3 sec to reset the air purifier, otherwise, the filter light will keep blinking.

Trouble Shooting

Problem	Reasons	Possible Solutions
Air purifier cannot be turned on or respond to button controls	No electricity	Check that the unit is properly plugged into an electrical outlet
	Power cord is damaged	Contact us for a new item
	The outlet is damaged	Plug into a different outlet
	The air purifier malfunctioned	Contact us for a new item
Airflow is significantly reduced	The airflow is blocked by packaging	Remove the packaging
	A low speed is used when the air is in the high pollution.	Increase the fan speed
	There is no enough clearance for the air comes in	Leave 20cm clearance on all sides of the air purifier
	The Pre-filter maybe clogged by large particles (air.,etc) so that the airflow is blocked	Clean the Pre-filter or replace the filter
	Filters has a wrong installation	Make the filters properly is in place.
Air purifier makes an unusual noise while the fan is on	The airflow is blocked by packaging	Remove the packaging
	The air purifier is in an inclined place making the fan blades rub with the air purifier's lining	Put the air purifier on even places
	The air purifier may be damaged, or a foreign object may be inside	Contact us for a new item

Trouble Shooting

Problem	Reasons	Possible Solutions
Strange smell comes from the purifier	The filters serve so long	Clean the filter or replace it
	The applied environment is with high humidity and so much dirtiness	Make sure not to use your purifier in an area with high humidity or while diffusing essential oils.
	There may be residual odors about the special cleanser used by manufacturers to make sure no dirtiness when you receive it.	Keep running it for 1 week
Poor air purification quality	A low speed is used When air is in the high pollution	Increase the fan speed
	The airflow is blocked by packaging	Remove the packaging
	The air outlet is blocked.	Remove any matter that is blocking the air outlet.
	Filters has a wrong installation	Make the filters properly is in place
	Use in open places	Close doors and windows while using the air purifier
	The applied area is larger than effective range	Consider a larger air purifier.
	The quality of the air in the room is very poor (such as a large number of people smoking).	Open the window to circulate new air. You may also need to replace the filter.
	The room layout is not good, which blocks the original air coming in and makes the purified air cannot be distributed uniformly	Buy more air purifiers or change the layout if possible

Trouble Shooting

Problem	Reasons	Possible Solutions
Air purifier always detects high levels of particulates	The unit is operating in a very dusty environment.	Consider turning the fan to HIGH
The filter light is still on after replacing the filter	Forget to reset the air purifier	Reset the air purifier by pressing the button of "Filter Light" for 3 seconds
The filter light isn't on within 8 months	The appliance is run infrequently or the air is in the high quality so that it takes longer to inform you	
The filter light is on before 6 months	The appliance is run frequently or the air is in the high pollution so that it takes shorter to inform you	Replace the filters

How Your Device Connects

- First-time setup works only on Wi-Fi, not Bluetooth or mobile data.
- After setup, you can switch off Wi-Fi – the device will auto-connect through mobile data or Bluetooth.
- Bluetooth works only within range; Wi-Fi and mobile data allow control from anywhere.
- When you return to Bluetooth range, it takes a few seconds to reconnect before control resumes.
- After a power reset, Wi-Fi, data, and Bluetooth all reconnect automatically; Bluetooth may need a few extra seconds.